

# GUIDES AND PROFILES

PROFILES C  
DRAWINGS PROFILES  
GUIDES FOR BELTS  
GUIDES FOR CHAINS  
LATERAL SUPPORT GUIDES

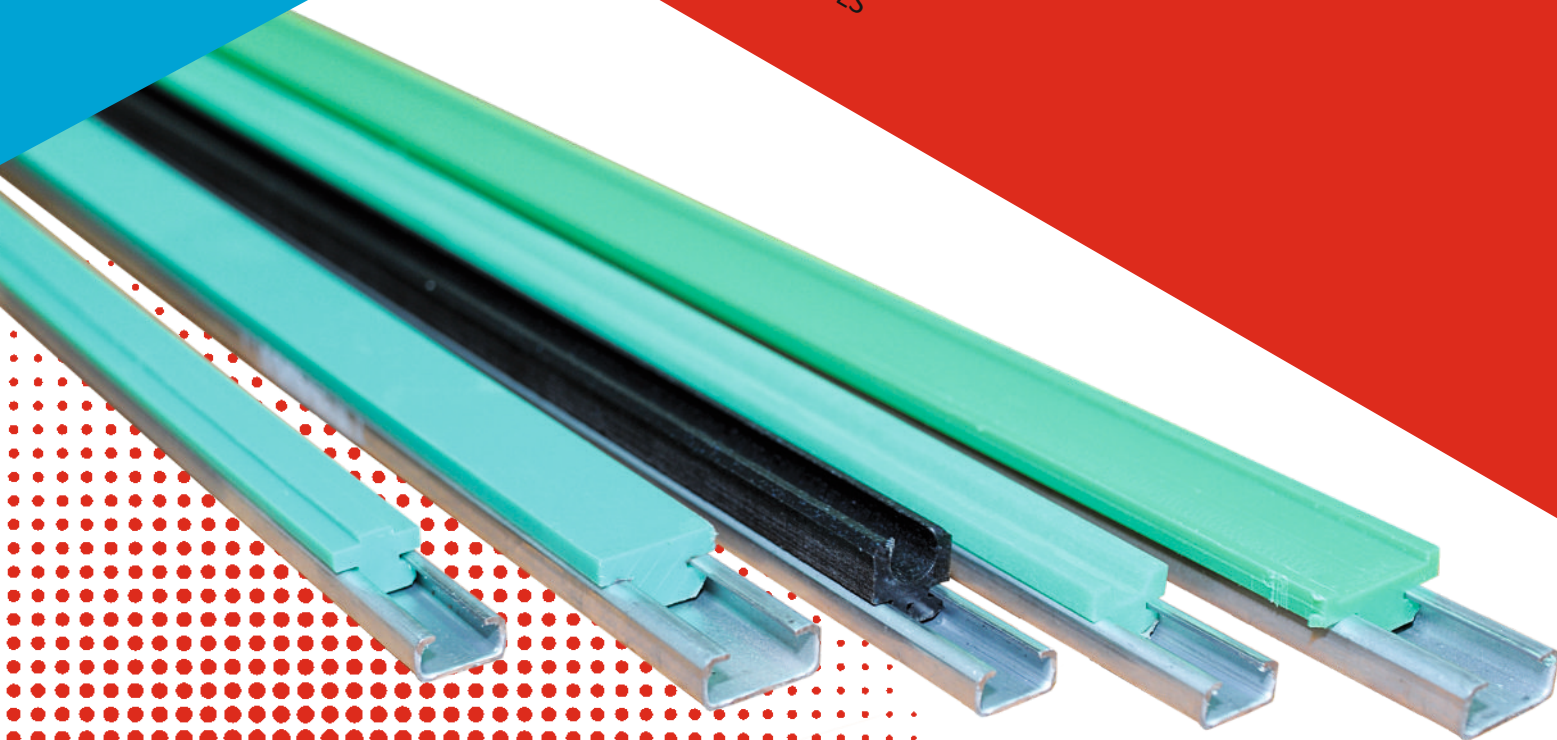

## Guide chains

## Lateral guide T1

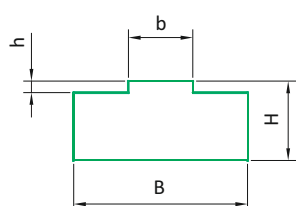
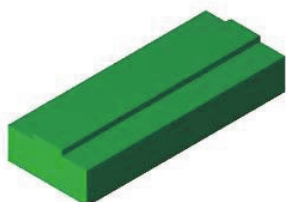

## Chain ISO

Type	Chain	Ref.ISO	B [mm]	H [mm]	b [mm]	h [mm]
T1-01	3/8"x7/32"	06-B1	15	10	5,4	1,5
T1-05	1/2"x2/16"	08-B1	20	10	7,4	2,2
T1-06	1/2"x5/16"	08-B1	20	15	7,4	2,2
T1-07	1/2"x5/16"	08-B1	20	20	7,4	2,2
T1-09	5/8"x3/8"	10-B1	20	10	9,2	2,6
T1-10	5/8"x3/8"	10-B1	20	15	9,2	2,6
T1-11	5/8"x3/8"	10-B1	20	20	9,2	2,6
T1-13	3/4"x7/16"	12-B1	25	10	11,3	2,4
T1-14	3/4"x7/16"	12-B1	25	15	11,3	2,4
T1-15	3/4"x7/16"	12-B1	25	20	11,3	2,4
T1-18	1"x17mm	16-B1	40	15	16,5	3,5
T1-19	1"x17mm	16-B1	40	20	16,5	3,5
T1-21	1 1/4"x3/4"	20-B1	45	15	19	4,3
T1-22	1 1/4"x3/4"	20-B1	45	20	19	4,3
T1-24	1 1/2"x1"	24-B1	60	15	24,6	5,6
T1-25	1 1/2"x1"	24-B1	60	20	24,6	5,6
T1-27	1 3/4"x31mm	28-B1	75	20	30	6,9
T1-30	2"x31mm	32-B1	80	20	30	7,8

## Chain ASA

Type	Chain	Ref. ASA	B [mm]	H [mm]	b [mm]	h [mm]
T1-51	3/8"x3/16"	ASA 35	15	10	4	2,2
T1-54	1/2"x5/16"	ASA 40	20	10	7,1	2,3
T1-55	1/2"x5/16"	ASA 40	20	15	7,1	2,3
T1-56	1/2"x5/16"	ASA 40	20	20	7,1	2,3
T1-58	5/8"x3/8"	ASA 50	20	10	8,6	2,7
T1-59	5/8"x3/8"	ASA 50	20	15	8,6	2,7
T1-60	5/8"x3/8"	ASA 50	20	20	8,6	2,7
T1-62	3/4"x1/2"	ASA 60	25	10	11,9	3,4
T1-63	3/4"x1/2"	ASA 60	25	15	11,9	3,4
T1-64	3/4"x1/2"	ASA 60	25	20	11,9	3,4
T1-66	1"x5/8"	ASA 80	40	15	15,1	4,5
T1-68	1"x5/8"	ASA 80	40	20	15,1	4,5

## Chain ISO

Type	Chain	Ref. ISO	B [mm]	h [mm]	b [mm]	h [mm]	P [mm]
T2-01	3/8"x7/32"	06-B2	25	10	5,4	1,5	15,8
T2-05	1/2"x5/16"	08-B2	35	10	7,4	2,2	21,4
T2-06	1/2"x5/16"	08-B2	35	15	7,4	2,2	21,4
T2-07	1/2"x5/16"	08-B2	35	20	7,4	2,2	21,4
T2-09	5/8"x3/8"	10-B2	40	10	9,2	2,6	25,8
T2-10	5/8"x3/8"	10-B2	40	15	9,2	2,6	25,8
T2-11	5/8"x3/8"	10-B2	40	20	9,2	2,6	25,8
T2-13	3/4"x7/16"	12-B2	45	15	11,3	2,4	30,8
T2-14	3/4"x7/16"	12-B2	45	20	11,3	2,4	30,8
T2-15	1"x17mm	16-B2	65	15	16,5	3,5	48,4
T2-18	1"x17mm	16-B2	65	20	16,5	3,5	48,4
T2-19	1 1/4"x3/4"	20-B2	70	15	19	4,3	54,5
T2-21	1 1/4"x3/4"	20-B2	70	20	19	4,3	54,5
T2-22	1 1/2"x1"	24-B2	88	20	24,6	5,6	73
T2-24	1 3/4"x31mm	28-B2	105	25	30	6,9	89,6
T2-25	2"x31mm	32-B2	105	30	30	7,8	88,7

## Lateral guide T2

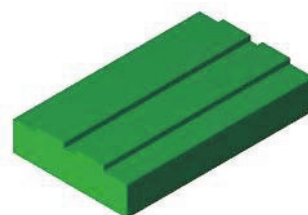

## Chain ASA

Type	Chain	Ref. ASA	B [mm]	H [mm]	b [mm]	b [mm]	P [mm]
T2-51	3/8"x3/16"	ASA 35.2	25	10	4	2,2	14,13
T2-55	1/2"x5/16"	ASA 40.2	35	10	7,1	2,3	21,48
T2-56	1/2"x5/16"	ASA 40.2	35	15	7,1	2,3	21,48
T2-57	1/2"x5/16"	ASA 40.2	35	20	7,1	2,3	21,48
T2-59	5/8"x3/8"	ASA 50.2	40	10	8,6	2,7	26,71
T2-60	5/8"x3/8"	ASA 50.2	40	15	8,6	2,7	26,71
T2-61	5/8"x3/8"	ASA 50.2	40	20	8,6	2,7	26,71
T2-63	3/4"x1/2"	ASA 60.2	45	10	11,9	3,4	34,68
T2-64	3/4"x1/2"	ASA 60.2	45	15	11,9	3,4	34,68
T2-65	3/4"x1/2"	ASA 60.2	45	20	11,9	3,4	34,68
T2-67	1"x5/8"	ASA 80.2	55	15	15,1	4,5	44,39
T2-68	1"x5/8"	ASA 80.2	55	20	15,1	4,5	44,39

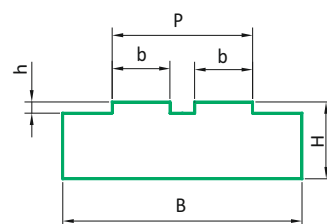

# Guide chains

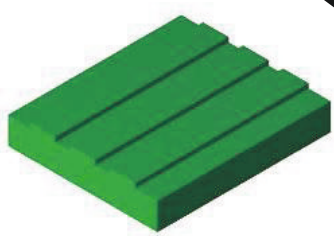

## Lateral guide T3

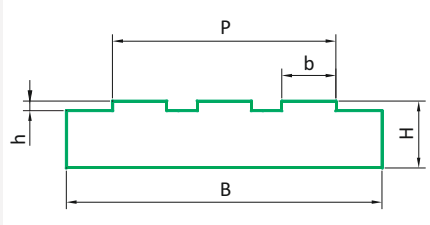

Type	Chain	Ref. ISO	B [mm]	H [mm]	b [mm]	h [mm]	P [mm]
T3-01	3/8"x7/32"	06-B3	35	10	5,4	1,5	25,9
T3-05	1/2"x5/16"	08-B3	45	10	7,4	2,2	35,2
T3-06	1/2"x5/16"	08-B3	45	15	7,4	2,2	35,2
T3-07	1/2"x5/16"	08-B3	45	20	7,4	2,2	35,2
T3-09	5/8"x3/8"	10-B3	55	10	9,2	2,6	42,4
T3-10	5/8"x3/8"	10-B3	55	15	9,2	2,6	42,4
T3-11	5/8"x3/8"	10-B3	55	20	9,2	2,6	42,4
T3-13	3/4"x7/16"	12-B3	60	15	11,3	2,4	50,2
T3-14	3/4"x7/16"	12-B3	60	20	11,3	2,4	50,2
T3-15	1"x17 mm	16-B3	95	20	16,5	3,5	80,3

## Lateral guide ET

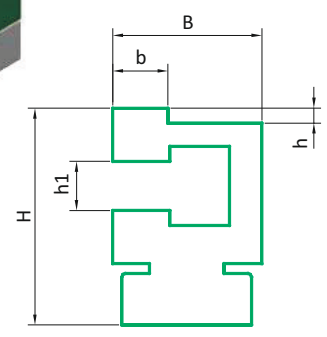
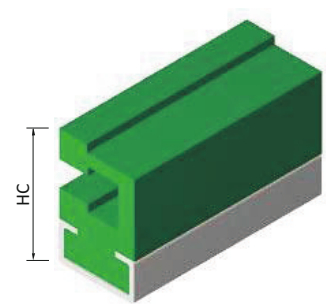

Type	Chain	Ref. ISO	Metallic profile	HC [mm]	B [mm]	H [mm]	h [mm]	h [mm]	h1 [mm]
ET-00	3/8"x7/32"	06-B1	C-3	28,7	20	26,4	5,4	1,4	6,6
ET-01	1/2"x5/16"	08-B1	C-3	30,5	20	28	7,4	2	8,7
ET-02	5/8"x3/8"	10-B1	C-3	36	20	34,1	9,2	2,5	10,4
ET-03	3/4"x7/16"	12-B1	C-5	41,5	24	38,5	11,3	2,3	12,3
ET-04	1"x17mm	16-B1	C-9	61,5	33,5	52,4	16,5	4,1	16,1

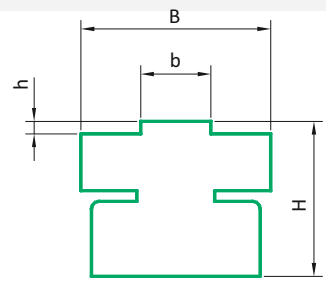
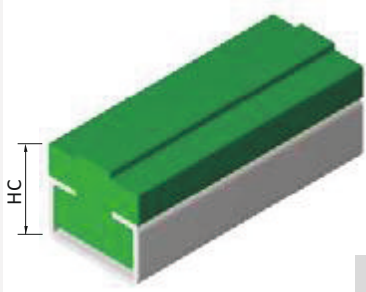

## Lateral guide T1C

Type	Chain	Ref. ISO	Metallic profiles	HC [mm]	B [mm]	H [mm]	b [mm]	h [mm]
T1C-31	3/8"x7/32"	06-B1	C-3	17	20	15	5,4	1,5
T1C-33	1/2"x5/16"	08-B1	C-3	17	20	15	7,4	2,2
T1C-34	5/8x3/8"	10-B1	C-3	17	20	15	9,2	2,6
T1C-35	3/4"x7/16"	12-B1	C-3	17	20	15	11,3	2,4
T1C-36	1"x17mm	16-B1	C-5	18	28	15	16,5	3,5
T1C-37	1 1/4"x3/4"	20-B1	C-9	27	38	20	19	4,3

## Lateral guide T2C

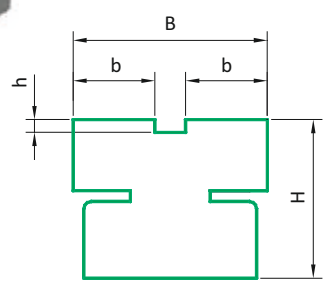
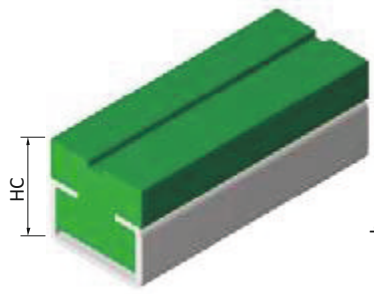

Type	Chain	Ref. ISO	Metallic profile	HC [mm]	B [mm]	H [mm]	b [mm]	h [mm]
T2C-31	3/8"x7/32"	06-B2	C-3	17	15,7	15	5,4	1,5
T2C-33	1/2"x5/16"	08-B2	C-3	17	21,4	15	7,4	2,2
T2C-34	5/8x3/8"	10-B2	C-5	19	25,9	15	9,2	2,6
T2C-35	3/4"x7/16"	12-B2	C-5	19	30,7	15	11,3	2,4
T2C-36	1"x17mm	16-B2	C-9	27	48,3	20	16,5	3,5

## Guide chains

### Guide E1

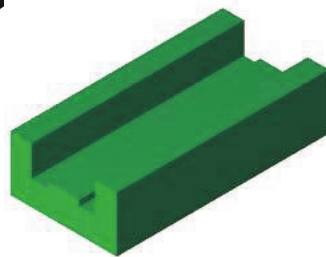
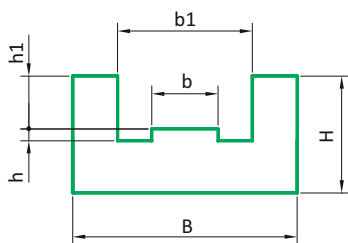

Type	Chain	Ref. ISO	B [mm]	H [mm]	b [mm]	h [mm]	h1 [mm]	b1 [mm]
E1-01	3/8"x7/32"	06-B1	25	10	5,4	1,5	15	4,4
E1-05	1/2"x5/16"	08-B1	30	15	7,4	2,2	20	7,2
E1-06	5/8"x3/8"	10-B1	33	20	9,2	2,6	23	9,5
E1-07	3/4"x7/16"	12-B1	38	20	11,3	2,4	28	11,1
E1-10	1"x17mm	16-B1	51	25	16,5	3,5	41	16,5

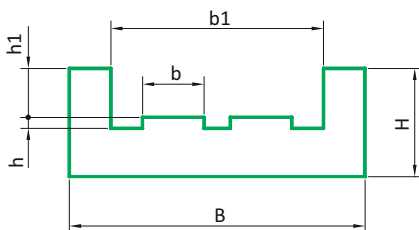
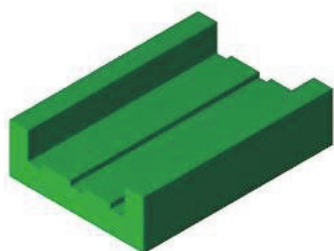

### Guide E2

Type	Chain	Ref. ISO	B [mm]	H [mm]	b [mm]	h [mm]	h1 [mm]	b1 [mm]
E2-01	3/8"x7/32"	06-B2	36	15	5,4	1,5	26	4,4
E2-05	1/2"x5/16"	08-B2	45	20	7,4	2,2	35	7,2
E2-06	5/8"x3/8"	10-B2	50	25	9,2	2,6	40	9,5
E2-07	3/4"x7/16"	12-B2	56	25	11,3	2,4	46	11,1
E2-10	1"x17mm	16-B2	85	30	16,5	3,5	75	16,5

### Guide E1C

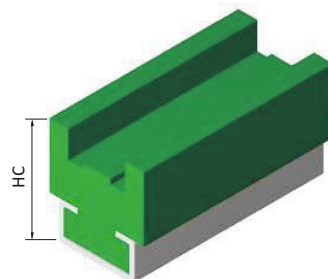
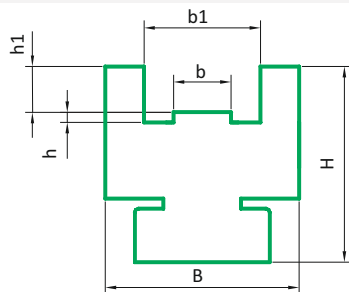

Type	Chain	Ref. ISO	Metallic profile	HC [mm]	H [mm]	B [mm]	b [mm]	h [mm]	b1 [mm]	h1 [mm]
E1-01	3/8"x7/32"	06-B1	C-3	20	25	18	5,4	1,5	15	4,4
E1-05	1/2"x5/16"	08-B1	C-3	27	30	25	7,4	2,2	20	7,2
E1-06	5/8"x3/8"	10-B1	C-5	32	33	30	9,2	2,6	23	9,5
E1-07	3/4"x7/16"	12-B1	C-9	38,5	38	35	11,3	2,4	28	11,1
E1-10	1"x17mm	16-B1	C-9	43,5	51	40	16,5	3,5	41	16,5

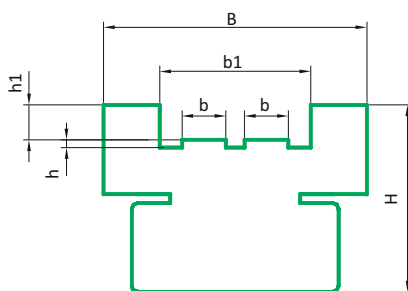
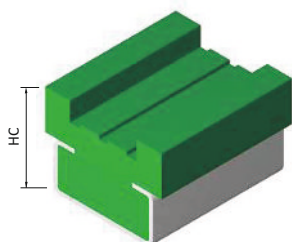

### Guide E2C

Type	Chain	Ref. ISO	Metallic profile	HC [mm]	H [mm]	B [mm]	b [mm]	h [mm]	b1 [mm]	h1 [mm]
E2C-01	3/8"x7/32"	06-B2	C-5	22	18	36	5,4	1,5	26	4,4
E2C-05	1/2"x5/16"	08-B2	C-9	33	25	45	7,4	2,2	35	7,2
E2C-06	5/8"x3/8"	10-B2	C-9	32	30	50	9,2	2,6	40	9,5
E2C-07	3/4"x7/16"	12-B2	C-9	38,5	35	56	11,3	2,4	46	11,1
E2C-10	1"x17mm	16-B2	C-9	43,5	40	86	16,5	3,5	75	16,5

Guide chains

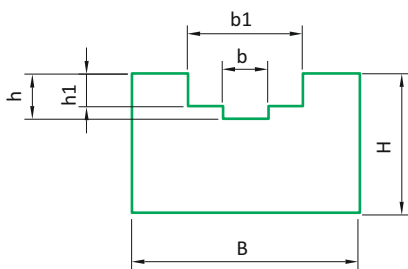
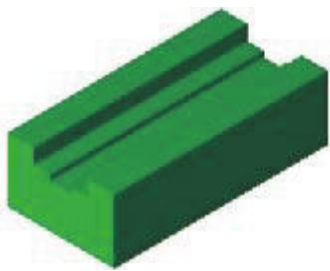

Guide U

Type	Chain	Ref. ISO	B [mm]	H [mm]	b [mm]	h [mm]	b1 [mm]	h1 [mm]
U-01	13/8"x7/32"	06-B1	20	15	9,2	4,2	4	2,8
U-02	1/2"x5/16"	08-B1	25	15	12,7	4,2	5	3,5
U-03	5/8"x3/8"	10-B1	25	15	15,2	5,1	6	3,6
U-04	3/4"x7/16"	12-B1	25	20	16,7	5,7	7	3,9
U-05	1"x17mm	16-B1	35	25	24,4	10	9	8,4

Guide UC

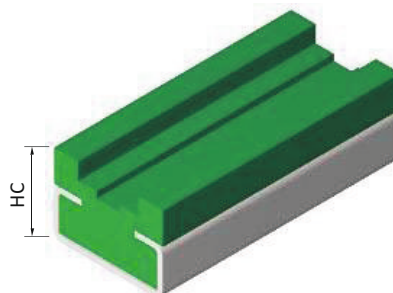
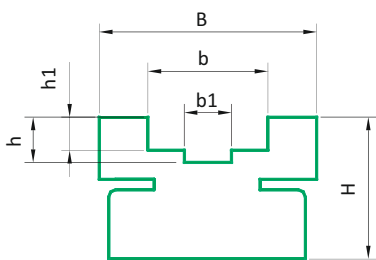

Type	Chain	Ref. ISO	Metallic profile	HC [mm]	B [mm]	H [mm]	b [mm]	h [mm]	b1 [mm]	h1 [mm]
UC-32	1/2"x5/16"	08-B1	C-3	18	20	15	12,7	4,8	5	3,5
UC-33	5/8"x3/8"	10-B1	C-3	18	23	15	15,2	5,1	6	3,6
UC-34	3/4"x7/16"	12-B1	C-3	23	23	20	16,7	5,7	7	3,9
UC-35	1"x17mm	16-B1	C-5	28	32	25	24,4	10	8	8,4

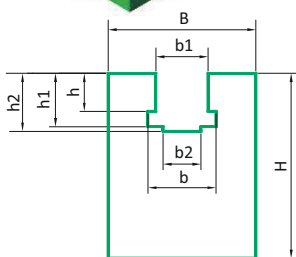

Guide BL

Type	Chain	Ref. ISO	B [mm]	H [mm]	b [mm]	h [mm]	b1 [mm]	h1 [mm]	b2 [mm]	h2 [mm]
BL-01	3/8"x7/32"	06-B1	20	25	9,3	5,6	6,6	8,7	4	10
BL-05	1/2"x5/16"	08-B1	24	30	12,8	7,6	8,7	11,5	5	13,5
BL-09	5/8"x3/8"	10-B1	30	35	15,4	9,5	10,4	13,5	6	14,8
BL-15	3/4"x7/16"	12-B1	40	35	16,9	11,5	12,3	15,9	7	17,5
BL-18	1"x17mm	16-B1	40	45	24,4	16,1	16,1	25,7	9	26,8
BL-21	1 1/4x3/4"	20-B1	50	50	27,5	19,4	19,3	29,3	11	31,2
BL-24	1 1/2"x1"	24-B1	60	60	36,5	25,2	25,7	38,2	16	40,1
BL-25	1 3/4"x31mm	28-B1	60	70	41,5	30,8	28,3	46,9	17	48,9
BL-30	2"x31mm	32-B1	70	75	44,5	30,8	29,6	47,3	19	53

Guide BLC

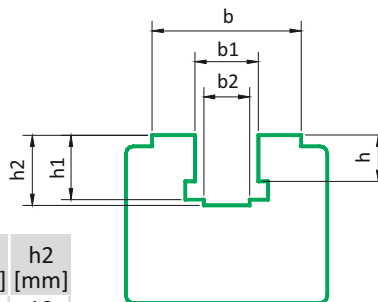
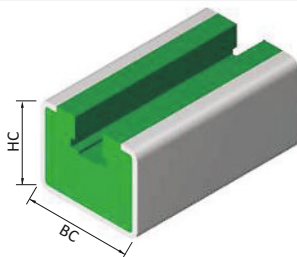

Type	Chain	Ref. ISO	Metallic profile	BC [mm]	HC [mm]	b [mm]	h [mm]	b1 [mm]	h1 [mm]	b2 [mm]	h2 [mm]
BLC-01	3/8"x7/32"	06-B1	C-10	30	24	19,8	5,6	6,6	8,7	4	10
BLC-05	1/2"x5/16"	08-B1	C-10	30	24	19,8	7,6	8,7	11,5	5	13,5
BLC-09	5/8"x3/8"	10-B1	C-10	30	24	19,8	9,5	10,4	13,5	6	14,8
BLC-15	3/4"x7/16"	12-B1	C-10	30	24	19,8	11,5	12,3	15,9	7	17,5
BLC-18	1"x17mm	16-B1	C-11	45	40	30,6	16,1	16,1	25,7	9	26,8
BLC-21	1 1/4x3/4"	20-B1	C-11	45	40	30,6	19,5	19,3	29,3	11	31,2

## Guide chains

### Guide KC

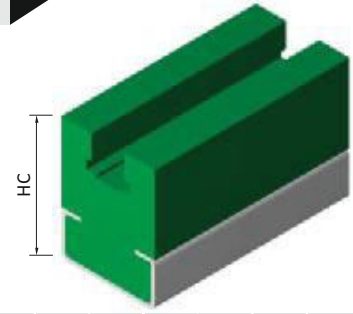
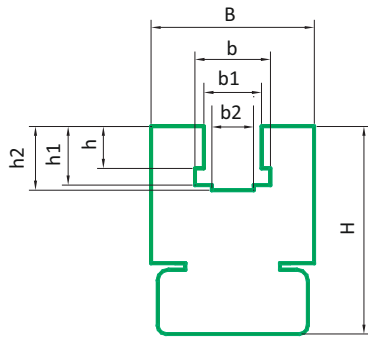

Type	Chain	Ref. ISO	Metal profile	HC [mm]	B [mm]	H [mm]	b [mm]	h [mm]	b1 [mm]	h1 [mm]	b2 [mm]	h2 [mm]
KC-01	3/8"x7/32"	06-B1	C-3	21	20	17,5	9,3	5,6	6,6	8,7	4	9,9
KC-02	1/2"x5/16"	08-B1	C-5	32	24	27,5	12,8	7,6	8,7	11,5	5	12,7
KC-03	5/8"x3/8"	10-B1	C-5	32	24	27,5	15,4	9,5	10,4	13,5	6	14,8
KC-04	3/4"x7/16"	12-B1	C-9	43	33	34	16,9	11,5	12,3	15,9	7	17,5
KC-05	1"x17mm	16-B1	C-10	50	38	40	24,4	16,1	16,1	25,7	9	26,8

### Guide BKC

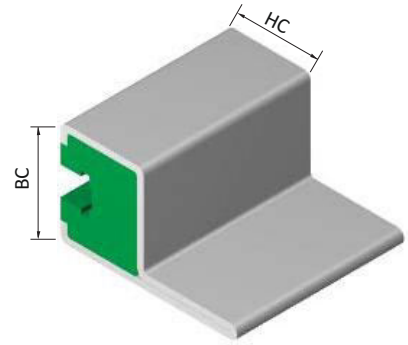
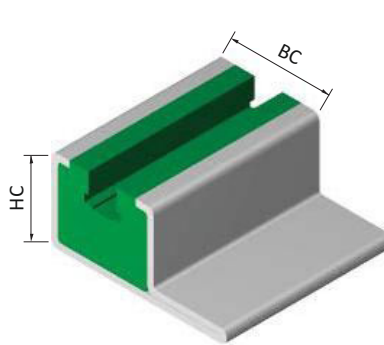
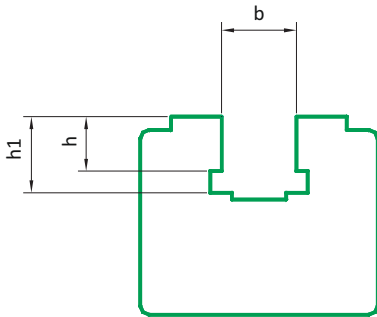

Type	Chain	Ref. ISO	Metallic profile	BC [mm]	HC [mm]	b [mm]	h [mm]	h1 [mm]
BKC-01	3/8"x7/32"	06-B1	C-14 / C-15	31	25	6,6	5,6	8,7
BKC-05	1/2"x5/16"	08-B1	C-14 / C-15	31	25	8,7	7,6	11,5
BKC-09	5/8"x3/8"	10-B1	C-14 / C-15	31	25	10,4	9,5	13,5
BKC-15	3/4"x7/16"	12-B1	C-14 / C-15	31	25	12,3	11	15,9

### Guide R

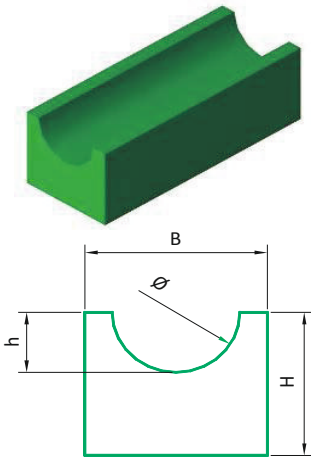

Type	Ø [mm]	B [mm]	H [mm]	h [mm]	Ø [mm]
R-01	4	15	10	2	4
R-03	5	15	10	2,5	5
R-05	6	20	10	3	6
R-07	8	20	10	4	8
R-09	10	25	12	5	10
R-11	12	25	12	6	12
R-13	15	25	15	7,5	15
R-15	20	30	20	10	20

### Guide RC

Type	Metallic profile	Ø [mm]	HC [mm]	B [mm]	H [mm]	h [mm]	Ø [mm]
RC-02	C-3	4	14	20	10	2	4
RC-04	C-3	5	14	20	10	2,5	5
RC-06	C-3	6	14	20	10	3	6
RC-08	C-3	8	14	20	10	4	8
RC-10	C-5	10	18	25	15	5	10
RC-12	C-5	12	18	25	15	6	12
RC-14	C-5	15	20	25	15	7,5	15
RC-16	C-5	20	24	28	20	10	20

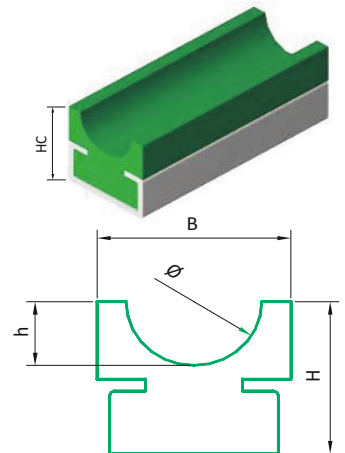

### Guide round belts Ø 12

Guide 99400

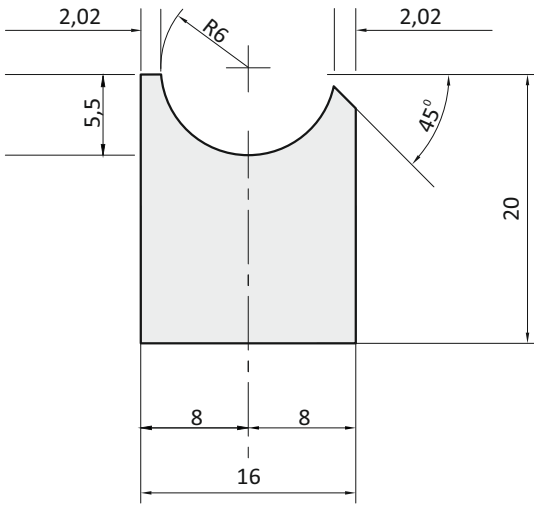

Guide 99401

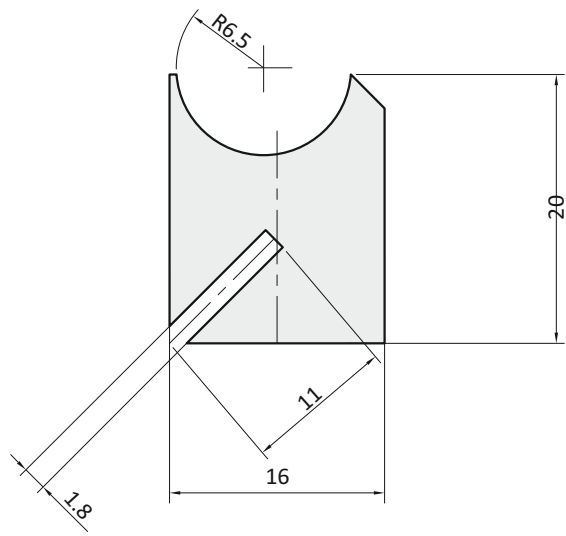

Guide 99403

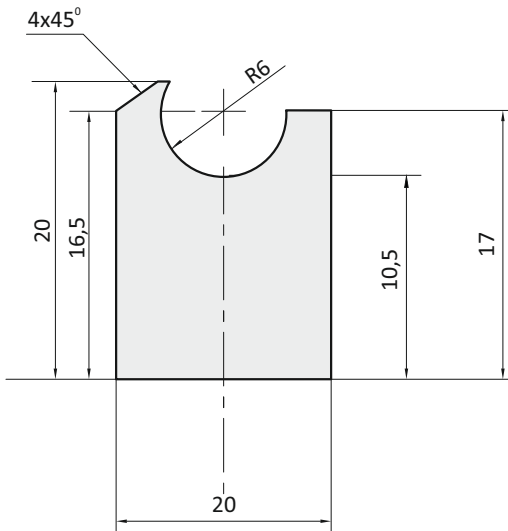

Guide 99405

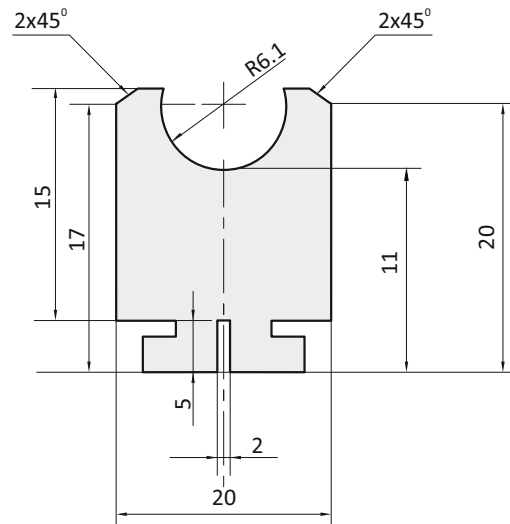

### Guide round belts Ø 10

Guide 99078

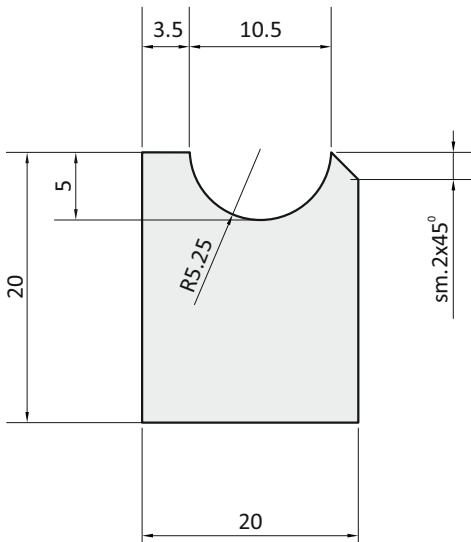

Guide 99529

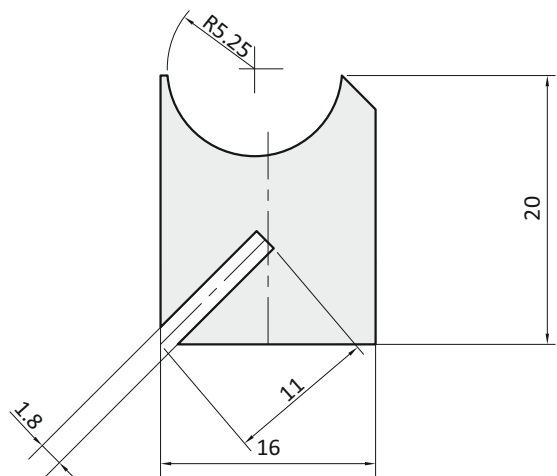

## Guide belts

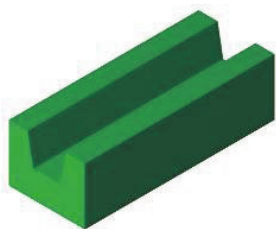

## Guide V

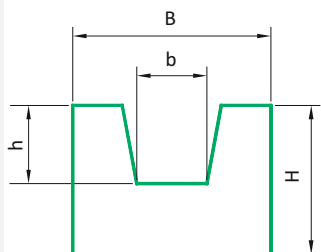

Typ	?	?	B [mm]	H [mm]	b [mm]	h [mm]
V-01	Z	10	20	10	6,5	3
V-03	A	13	20	12	8	5
V-05	SPB	15	25	12	9,5	5
V-07	B	17	30	15	10,5	8
V-09	C	22	35	20	13,5	11
V-11	D	30	40	25	19	13

## Guide VC

TypE	Metallic profile	?	?	HC [mm]	B [mm]	H [mm]	b [mm]	h [mm]
VC-02	C-3	Z	10	17	20	15	6,5	3
VC-04	C-3	A	13	17	20	15	8	5
VC-05	C-5	SPB	15	24	25	20	9,5	5
VC-08	C-5	B	17	24	30	20	10,5	8
VC-10	C-9	C	22	32	35	25	13,5	11
VC-12	C-9	D	30	35	40	25	19	13

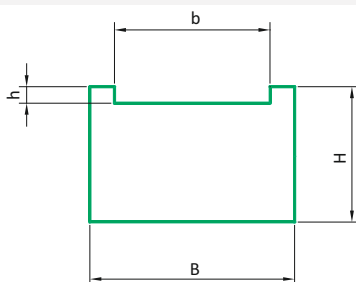
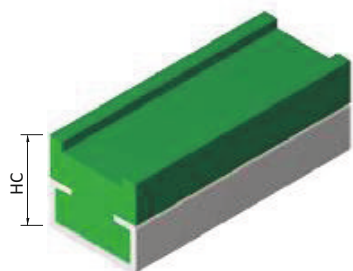
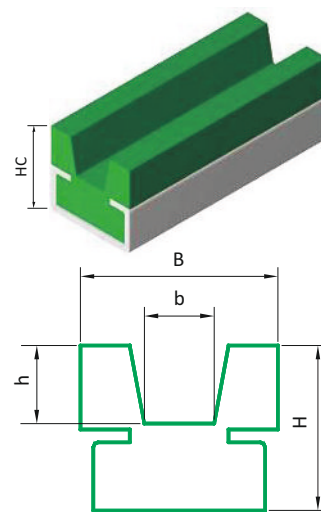

## Guide F

## Guide PC

Type	Metallic profile	B [mm]	H [mm]	h [mm]	HC [mm]
PC-01	C-3	20	10	4	14
PC-02	C-3	20	15	7	17
PC-03	C-3	20	20	12	22
PC-04	C-5	28	10	3	15
PC-05	C-5	28	15	6	18
PC-06	C-5	28	20	12	24
PC-07	C-9	38	10	3	21
PC-08	C-9	38	15	6	24
PC-09	C-9	38	20	12	30

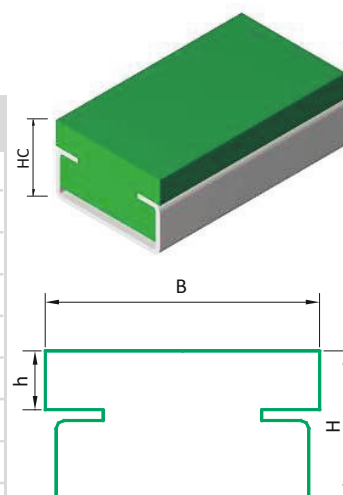



## Steel guide

Guides steel strip under the B-C from stainless steel AISI 304 or of galvanized length 3000 and 6000 mm

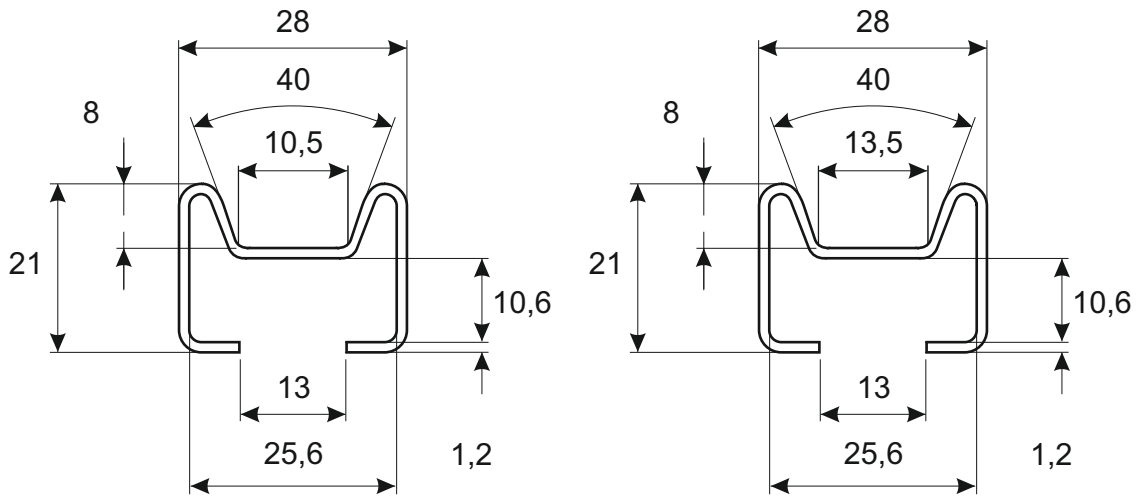

## Aluminium structural profiles

Profiles L 3000 e 6000 mm

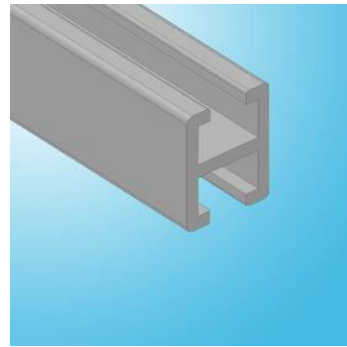
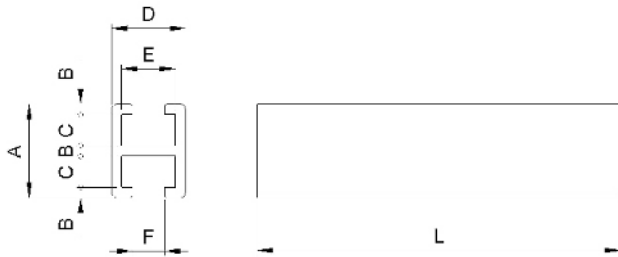

A [mm]	B [mm]	C [mm]	D [mm]	E [mm]	F [mm]	G [mm]
14,2	10,4	6,2	18	2	6	2

Square profile 10-10  
Rectangular profile 10-15  
L 3000 e 6000mm

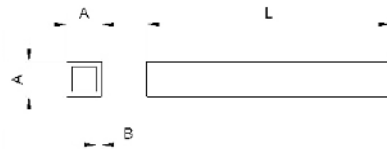
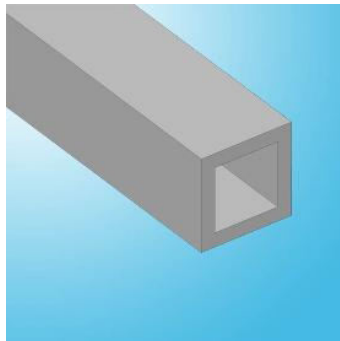

Profile	Square	Rectangular
A [mm]	10	10
B [mm]	10	15
C [mm]	1,5	1,5

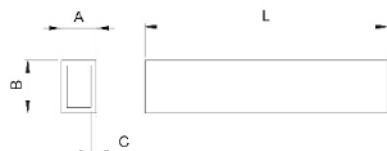
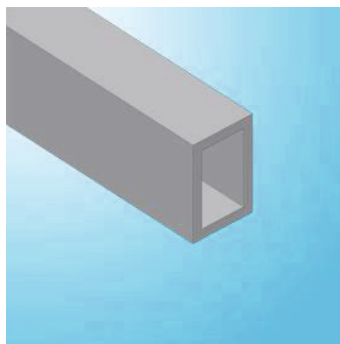

## Guides GTC

Aluminium profile with a guide GTC polyethylene trapeze belt B-C length 3000-6000 mm

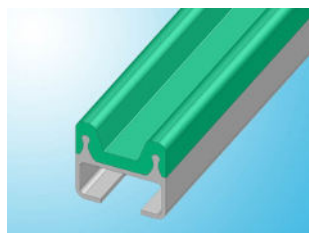
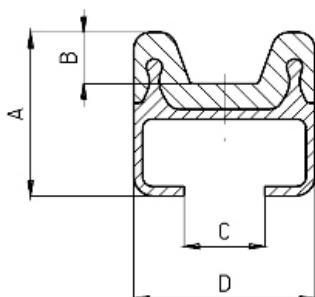

Profile GTC	A [mm]	B [mm]	C [mm]	D [mm]
pod pas B	25,5	8	12,5	28
pod pas C	25,5	8	12,5	28

Aluminium profiles with a guide GTC polyethylene under round belt L3000 e 6000

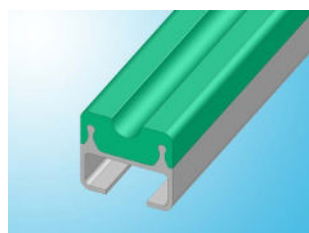
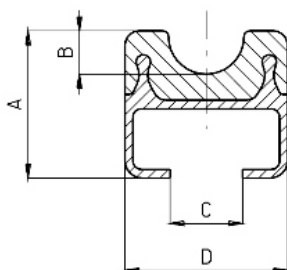

Profile GTC	A [mm]	B [mm]	C [mm]	D [mm]
pod pas D.12	25,5	6,5	12,5	28
pod pas D.10	25,5	5,5	12,5	28
pod pas D.8	25,5	4,5	12,5	28

Aluminium profile with a flat guide GTC L3000 e 6000

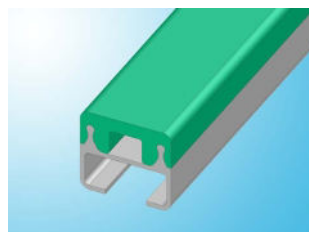
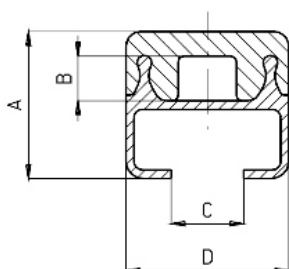

A [mm]	B [mm]	C [mm]	D [mm]
25,5	7,8	12,5	28

## Diamond guides

- Diamond guide and Diamond plus guides under the belt B-C
- Diamond guide made of polyethylene with a higher coefficient of slip
- Diamond plus guides made of polyethylene a higher coefficient of slip and increased resistance to abrasion

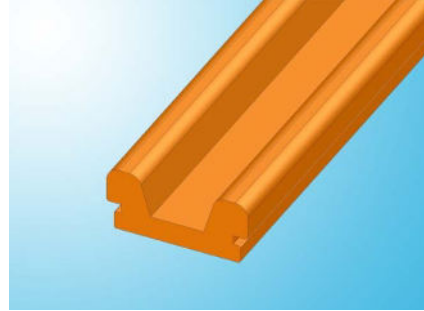
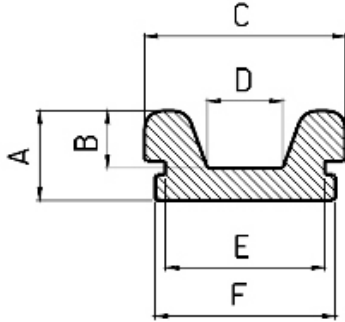

Guide	A [mm]	B [mm]	C [mm]	D [mm]	E [mm]	F [mm]
pod pas B	12,5	8	28	10,5	22	24,9
pod pas C	12,5	8	28	13,5	22	24,9

## Aluminium profile

Aluminium profile (5607) for diamond guides and diamond plus guides

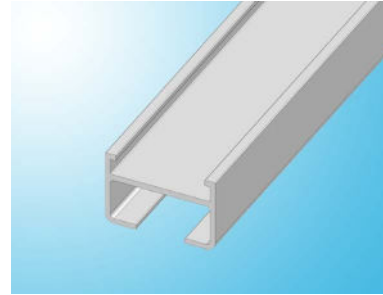
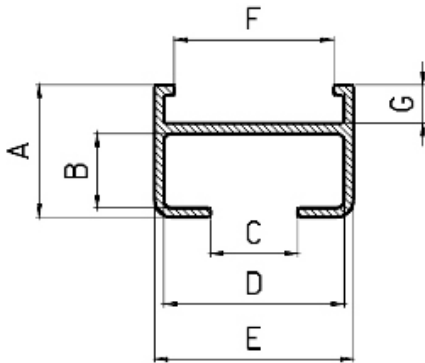

A [mm]	B [mm]	C [mm]	D [mm]	E [mm]	F [mm]	G [mm]
18,75	10,5	12,3	25,4	28	22,5	4

## Lateral guides

Profile LK20

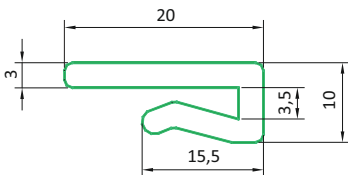

Profile LK25

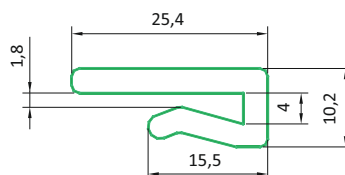

Profile LK40

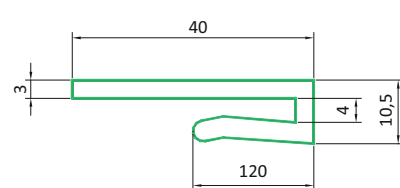

Thick s (mm)	length rolls (m)	Width guide B												
		10	20	25	30	35	40	45	50	60	70	80	100	
2	117	•	•	•	•	•	•	•	•	•	•	•	•	•
3	82	•	•	•	•	•	•	•	•	•	•	•	•	•
4	60	•	•	•	•	•	•	•	•	•	•	•	•	•
5	48	•	•	•	•	•	•	•	•	•	•	•	•	•
6	38	•	•	•	•	•	•	•	•	•	•	•	•	•

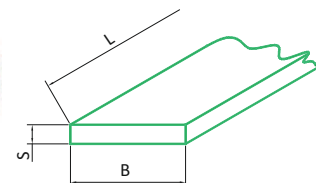

Still profiles

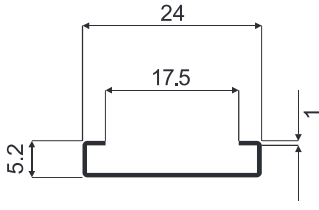

C1

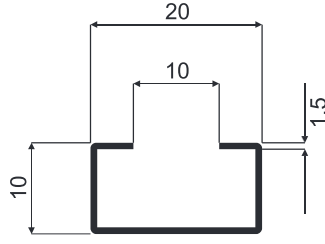

C3

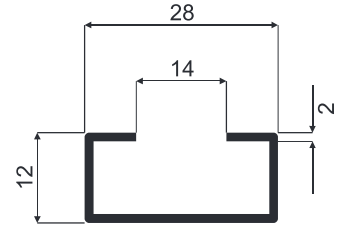

C5

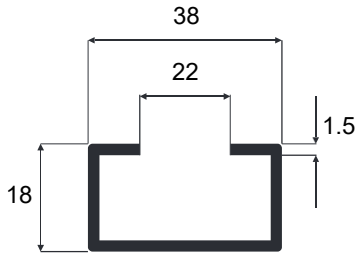

C9/1.5

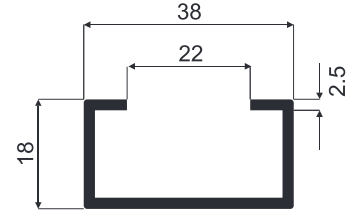

C9

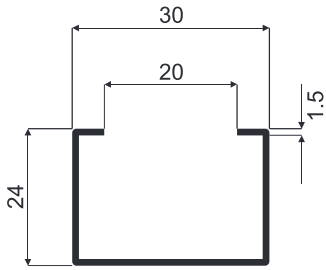

C10

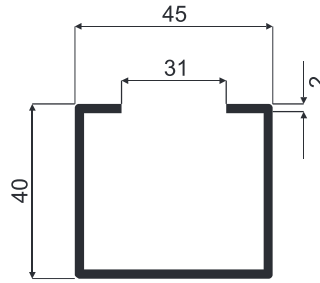

C11

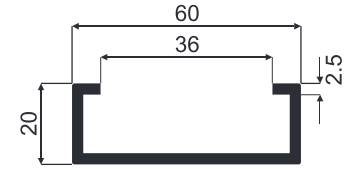

C12

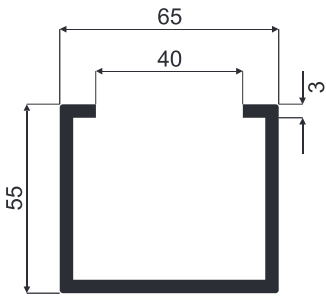

C13

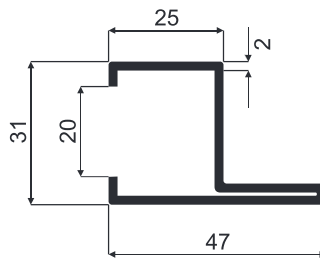

C14H

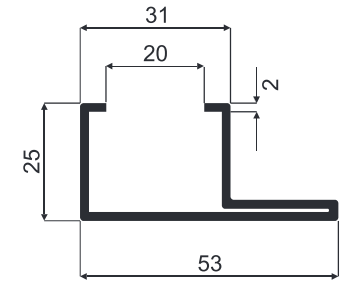

C15V